



# E-12



Machine weight: 1000 kg

Bucket capacity: 0.02 m<sup>3</sup>

Engine power: 7.6/3000 kW/rpm

- Simple Structure
- Easy pilot control
- High safety standard

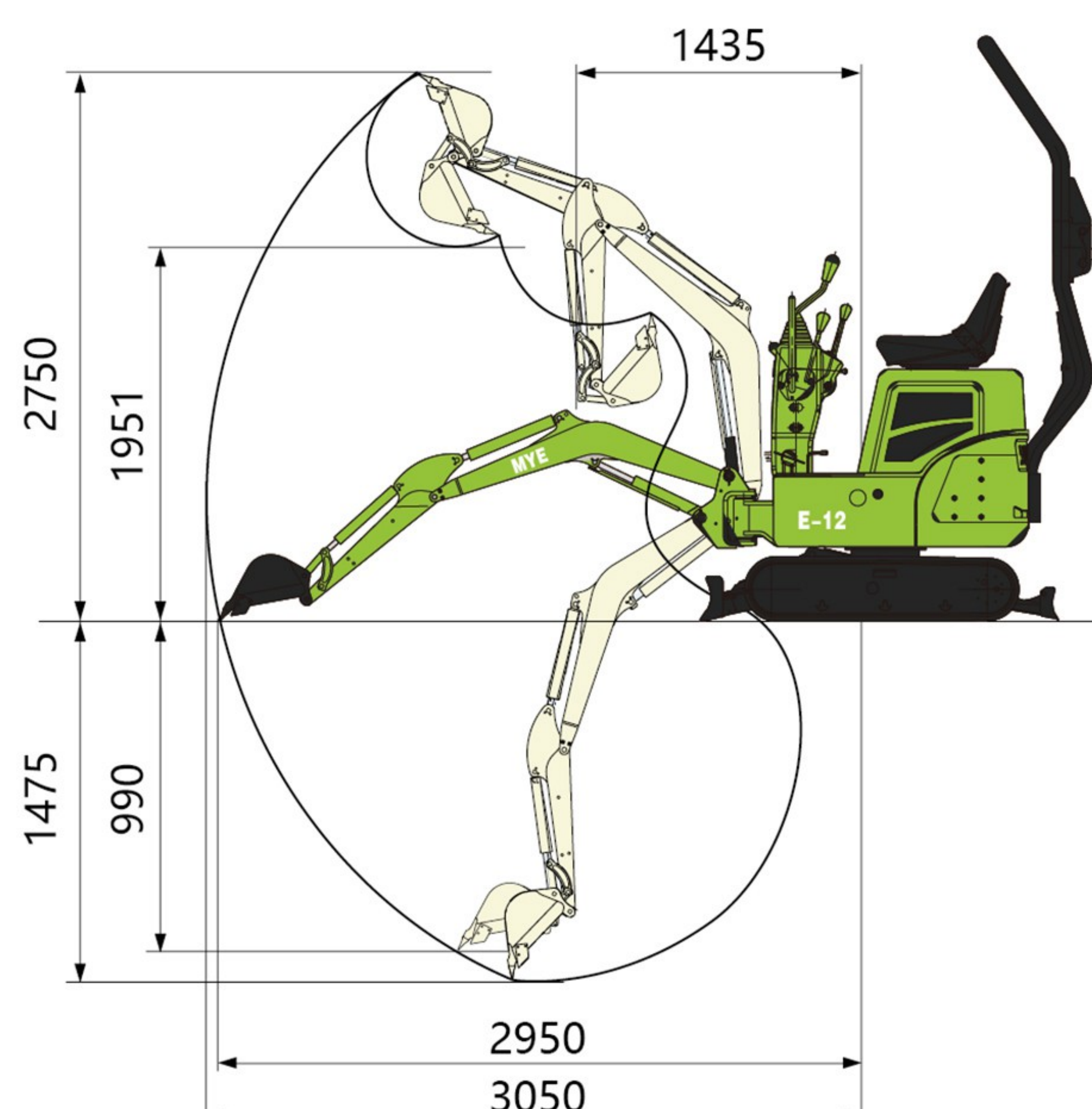
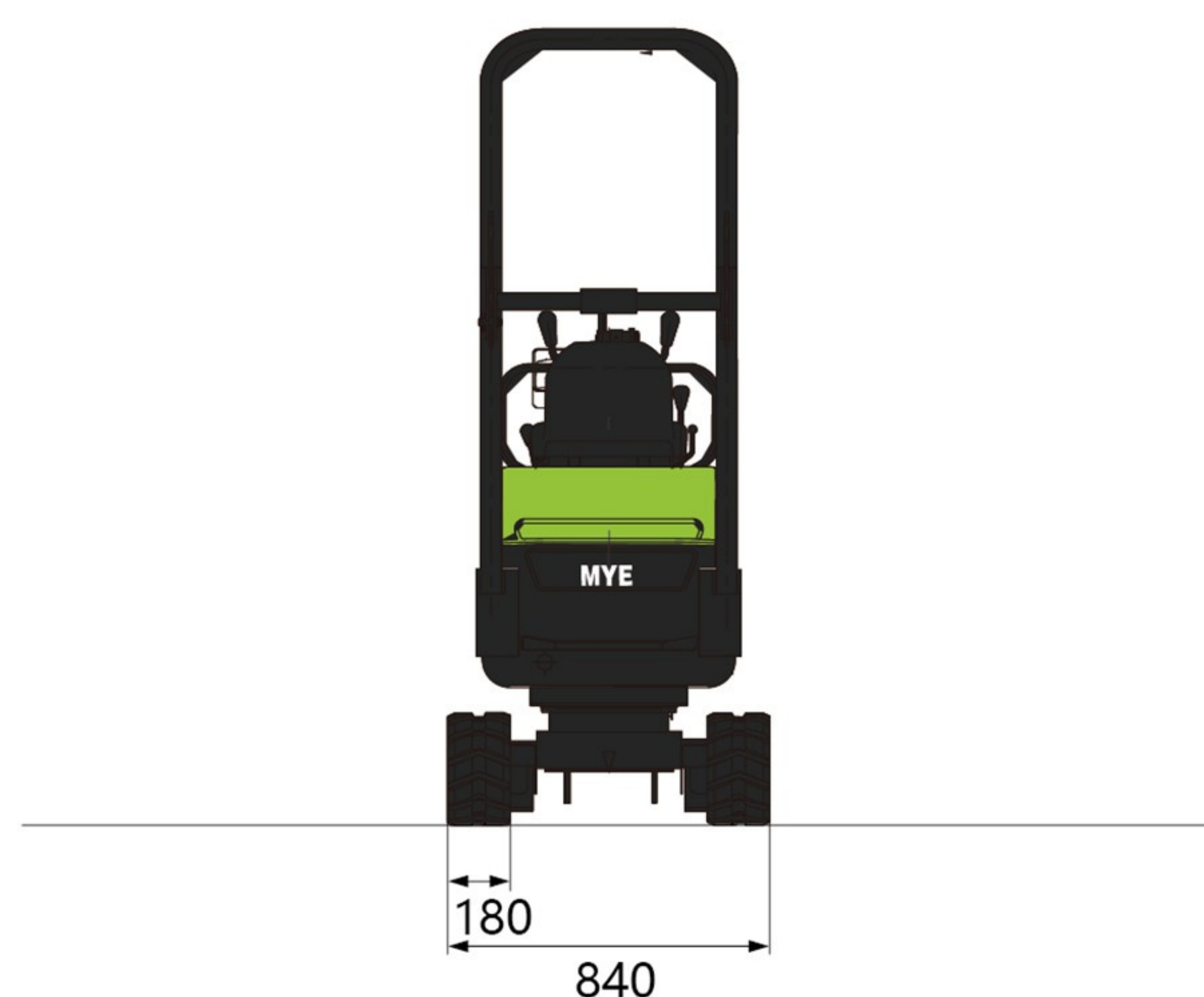
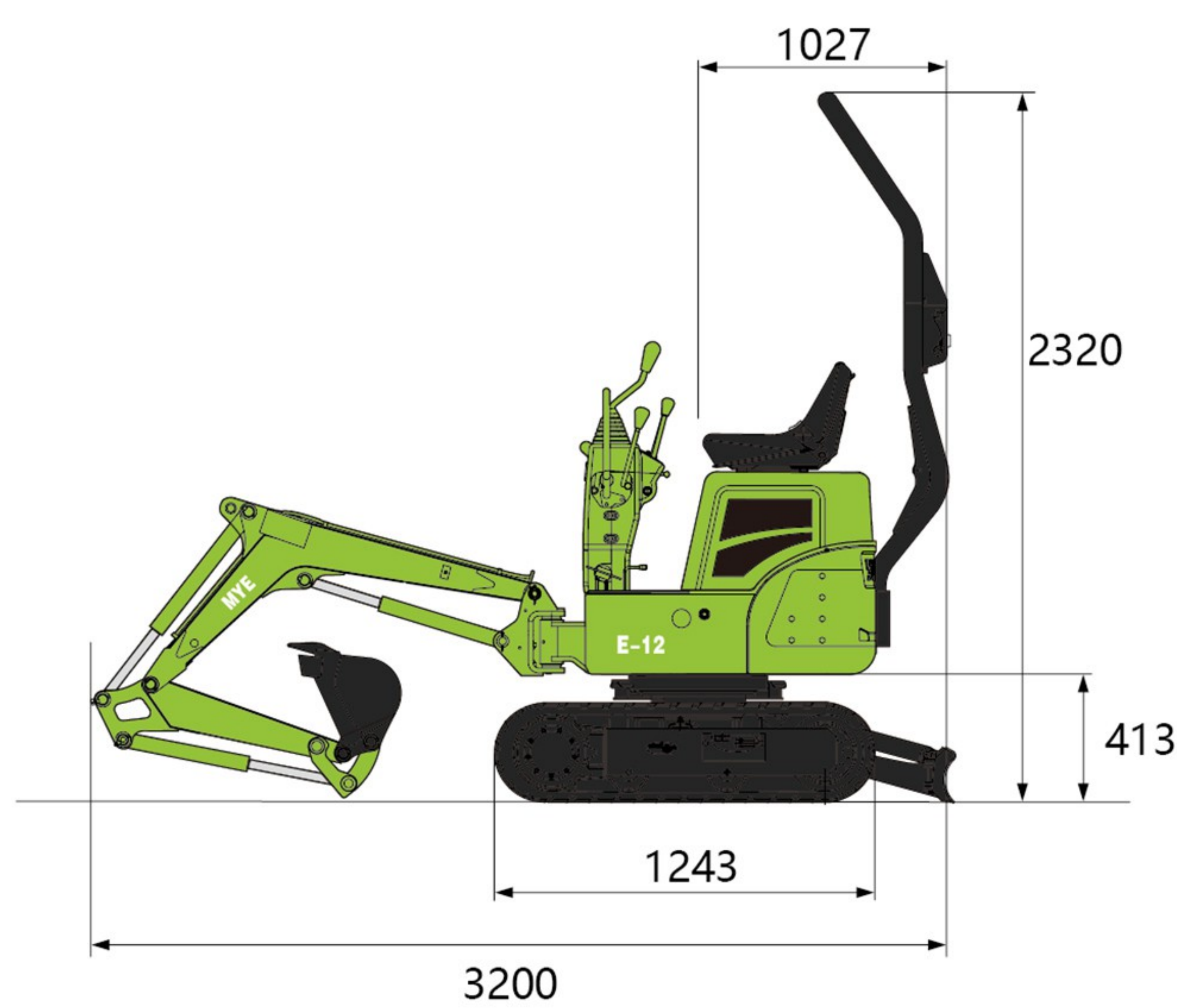

## Technical Specification

Basic parameter	
Machine weight	1000 kg
Bucket capacity	0.02 m <sup>3</sup>
Width of bucket	356 mm
Performance parameter	
Engine model	Koop KD192F
Engine power	7.6/3000 kW/rpm
Max. Gradeability	26.6 °
Max. digging force of arm	6.73 kN
Max. digging force of bucket	8.38 kN
Traveling speed	1±0.2 km/h
Max. hauling force	9.6 kN
Slewing speed of platform	9-12 rpm
Operating parameter	
Max. digging height	2750 mm
Max. digging depth	1475 mm
Max. digging radius	3050 mm
Max. digging radius on ground level	2950 mm
Max. dumping height	1951 mm
Min. slewing radius	1435 mm
Max. vertical digging depth	990 mm
Transportation dimension	
Overall length	3200 mm
Overall width	840 mm
Overall height	2320 mm
Other Parameter	
Width of undercarriage	840 mm
Length of track	1243 mm
Width of track	180 mm
Height between undercarriage and ground	158 mm
Height between platform and ground	413 mm
Platform tail turning radius	1027 mm
Track gauge	895 mm
Fuel tank capacity	10 L
Hydraulic oil tank capacity	13 L
Flow rate of pump	24 L/min

Guangxi Yuchai Heavy Industry Co.,Ltd.  
Address: No.168 Tianqiao Road, Yulin, Guangxi, China  
Tel: +86-775-3223503  
Fax: +86-775-3223503  
Email: dig@yuchai.cn, ychi-export@yuchai.cn  
Website: www.yuchaihi.com  
Alibaba Website: www.yuchaihi.en.alibaba.com

Specifications are subject to change without prior notice