

Global first wheel side motor driving technology
 Global first wheel side AUTO-HOLD technology
 Integrated chassis
 Battery life increased by **32%**

Safe & Reliable

Battery Advantages

30000 Working Hours

16 Years Working Life



Saving **90%** on fuel costs
Zero maintenance during **2000** hours
 Low failure rate

S35Pro/S35Max-Electric Skid Steer Loader

The Yuchai S35Pro/S35Max electric skid steer loader features with global first wheel side motor driving and AUTO HOLD technology, ensuring stability, reliability, and safety. Its compact design and excellent maneuverability make it ideal for extremely narrow spaces, easily navigating corridors, aisles, alleys, and low-height areas. It can be equipped with various attachments for functions such as loading, sweeping, and crushing.

The S35Max long-endurance version offers fast charging in just 1 hour, allowing for 8-9 hours of continuous operation.

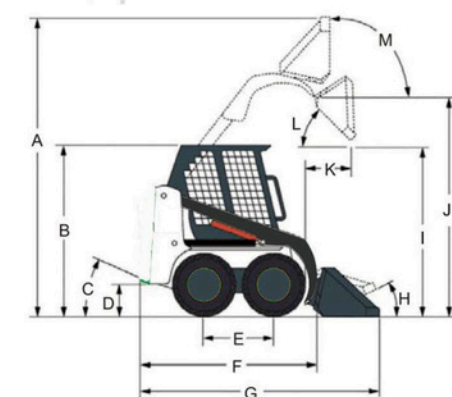
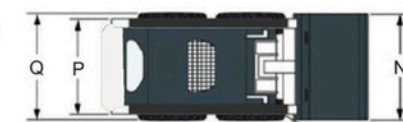

Performance Parameters

Basic parameter		S35Pro	S35Max
Machine Weight	kg	1540	1620
Bucket capacity	m ³	0.29	0.29
Bucket width	mm	1126	1126

Technical Specification

Battery		Lithium Iron Phosphate	Lithium Iron Phosphate
Rated power	kW/rpm	9/3150+4×2/3500	9/3150+4×2/3500
Max. torque/speed	N.m/N.m	70N.m/1500+4×36.8N.m/995 rpm	70N.m/1500+4×36.8N.m/995 rpm
Battery capacity	kWh	21.29	29.17
Rated Operating Load	kg	350	350
Tipping Load	kg	700	730
System working pressure	MPa	33.7	33.7
Flow Rate	L/min	20.5 (0~+0.5)	20.5 (0~+0.5)
Increase maximum digging force	kN	8	8
Tipping	kN	9	9
Max. travel speed(low gear)	km/h	0~10.5	0~10.5
Fast charge		1 hour Charging from 30% to 80%	1 hour Charging from 30% to 80%
Endurance*	h	6~8	8~9

Drive System

Wheel side motor driving
 Wheel side Auto Hold

Operating parameter

A Overall operating height	mm	3245	3245
B Height to top of cab	mm	1815	1815
C Dumping angle at maximum height	°	25/22	25/22
D Ground clearance	mm	141	141
E Wheelbase	mm	722	722
F Overall length without standard bucket	mm	1952	1952
G Overall length with standard bucket	mm	2682	2682
H Maximum angle of flat ground	°	22	22
I Unloading height	mm	1850	1850
J Height to bucket hinge pin	mm	2410	2410
K Loading distance at Max. unloading height	mm	545	545
L Dumping angle at maximum height	°	34	34
M Rollback of bucket at full height	°	97	97
N Bucket width	mm	1126	1126
O Radius of gyration	mm	1650	1650
P Tread	mm	756	756
Q Machine width	mm	959	959

*According to YuchaiHI standard testing conditions.
 Specifications are subject to change without prior notice.