

LM920 / 3.2M

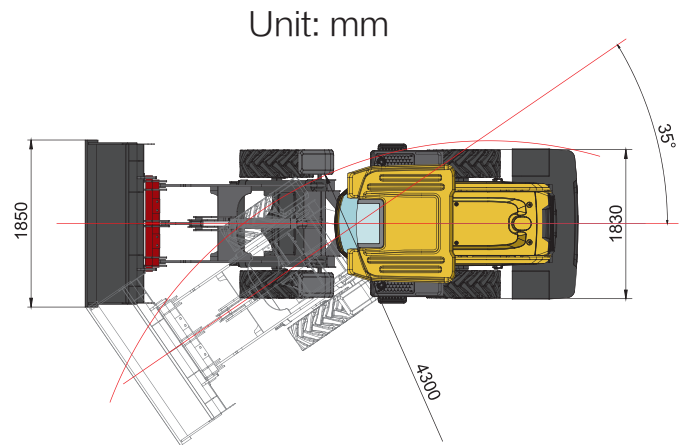
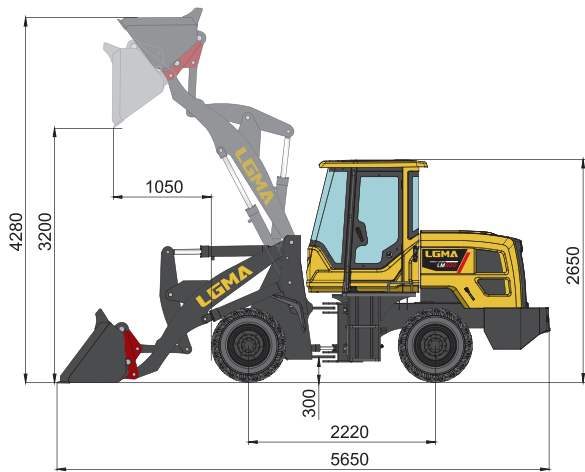

Unit: mm

Main Specifications

TECHNICAL PARAMETER	
Rated load	1600kg
Operating weight	3800kg (Filling counterweight)
Bucket capacity	0.8m ³
Bucket width × Bucket depth	1900mm × 500mm
Overall dimension (L × W × H)	5800mm × 1830mm × 2650mm
Wheel base	2220mm
Wheel track	1500mm
Max.dumping height	3200mm
Max.dumping distance	1050mm
Turning radius	5000mm
Min ground clearance	300mm

TRANSMISSION SYSTEM	
Type	265 Integral H/L Speed
Pattern	Automatic, Mechanical gear change
Pattern (Options)	Automatic, Electronically gear change
Radiator	Large hole double row
Auxiliary water tank	Standard
Prefilter	Dual air filter

HYDRAULIC SYSTEM	
Lifting time	4S
Falling time	3S
Total cycling time	10S
Working pump	1040 Left-hand Spline key
Walking pump	316 Left-hand Spline key
Steering gears	200A
Distributor	15.2, 40L/min
Priority valve	200
Pump and valve integrated	NO
Oil pipe	24° Tapered
Fuel tank	New style fuel tank

DRIVE AXLES	
Axle	LG Small Wheel Hub Reduction Cast Steel Disc Brake Axle
Articulated	Double layer

ENGINE	
Standard engine	YUNNEI 490 (42kw)

BRAKE SYSTEM	
Operating type	Mechanical single joystick
Control mode (Optional)	① Single hydraulic joystick ② Electrical hydraulic joystick
Brake booster pump	Two-way air brake

WHOLE CAR COVERING PARTS	
Color	Customization
Stamped and stretched front hood	Yes
Stamped and stretched rear hood	Yes, Side flip type (T type)
Stamped and stretched counterweight	Yes
Quick-hitch	Optional
Seat	Luxury Seat
Dashboard	LCD Dashboard
Dashboard (Optional)	Adjustable LCD
Air conditioner (Optional)	① Cold A/C ② Heating and cooling A/C
Battery	24V, 60A
Reversing camera	Optional, Customizable start-up screen
Warning lights	Standard
Reverse horn	Standard
Timer	Standard
Radios	Standard
Tool box	Export-specific toolbox

TYRE	
Tyre (Standard)	20.5 / 70-16

GRAIN BUCKET			
Unloading height	Bucket width	Depth	Capacity
3500mm	1900mm	700mm	1.6m ³
3800mm	1900mm	700mm	1.6m ³
4500mm	1900mm	800mm	1.7m ³