

ZOOMLION TECHNOLOGY WITH INGENUITY AND CARE



THE WORLD'S LEADING EXCAVATOR INTELLIGENT MANUFACTURING FACTORY

ZOOMLION Smart City Earthmoving Machinery Park is an industry-leading intelligent and flexible excavator factory. From a piece of steel plate to an excavator, with high-precision welding process, highly reliable assembly process, high-level coating process and strict quality control, each excavator is delivered with ultimate quality.



DJJ Equipment

NSW - 100 Derby Street, Silverwater NSW 2128
WA - 56 Clavering Road, Bayswater WA 6053
QLD - 65-67 Beal Street, Meadowbrook QLD 4131

TEL: 1800 355 388
Email: sales@djjequipment.com.au



ZOOMLION SKID-STEER LOADER ZS030R



ZOOMLION



**VISION
CREATES
FUTURE**



PRODUCT ADVANTAGES

EXCELLENT PERFORMANCE AND POWERFUL ENGINE

Powerful engine equipped with dual throttle control realizes perfect match-up of performance and economy

- Flexible & Light
- Excellent performance
- Safe & Comfortable
- Convenient maintenance
- Distinguished & Durable
- Multiple functions

Rated loading capacity (50%) : 345 kg
Bucket breakout force : 8.7 kN
Operating weight : 1293 kg
Kubota 18.2 kW engine
Tipping load 690 kg

Manual fixed throttle

Continuous operation keeping engine constant speed

Pedaling dynamic throttle

Occasional actions increasing engine speed instantaneously

Wide applicability

Meeting Euro V and EPA Tier IV emission regulations, applicable to regulatory requirements

A Pedaling dynamic throttle

B Manual fixed throttle

- Kubota 18.2kW engine, completes complicated working tasks with strong power;
- Manual fixed throttle and pedaling dynamic throttle control balance the demands of power and fuel economy;
- It meets Euro V and EPA Tier IV emission regulations.



INDEPENDENT COOLING SYSTEM, ECONOMIC & ENERGY SAVING

It adopts independent cooling technology, adjusting cooling capability automatically according to the temperature, which is more energy saving



FLEXIBLE, LIGHT & STRONG PASSABILITY

Primary choice for construction in narrow spaces

- Overall length without attachments is **1.89m**; overall height is **1.81m**; overall width is **0.91m**; it is convenient for conveyance and easy to get in the elevator.
- The ground clearance of machine is **140mm**, and the angle of departure is **25°**, meeting the demands of busy construction sites.
- **10.3km/h** standard highest traveling speed, can meet the demands of quick conveyance.
- With pivot steering and small turning radius, it is capable of working in narrow spaces, replacing man labor and improving the construction efficiency.



OUTSTANDING LOADING AND DUMPING CAPABILITY

Load more, lift higher and move quicker

- The rated load of the whole machine; (50%) is 345kg, the tipping load is 690kg, and the shovel loading efficiency is higher
- Height of bucket hinge pin: **2420mm**;
- Maximum height of bucket bottom level: **2245mm**, dump angle: **34°**, easy to load and dump;
- Large flow hydraulic system: **38L/min**, efficiency of work equipment improved by **18%**, loading and unloading efficiency improved by **24%**.

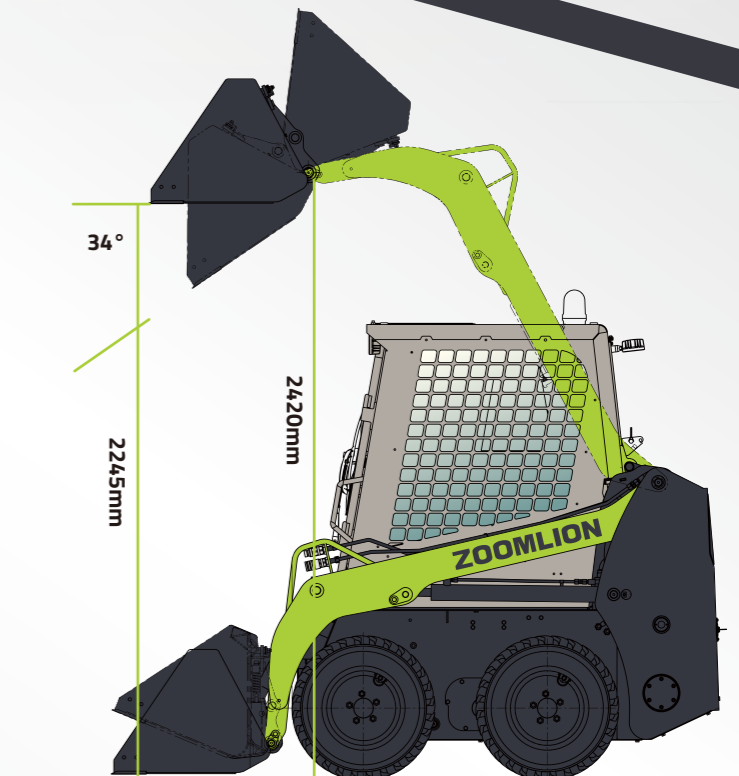

SAFETY & RELIABILITY

Unique design, ensuring your construction safety

- Working arm sunken design brings better side view and safer construction;
- Operating weight 1293 kg, reduces the load of floor slab to full extent when constructing upstairs.



- Bucket cylinders and pipelines are equipped with protective cover to prevent from being damaged.



- Standard FOPS/ROPS cab with safe certification, ensuring the safety of drivers.



DISTINGUISHED DURABILITY

Comfortable driving experience



- Integral muffler structure, lowering vibration with less noise
Air inlet of muffler connecting with the engine exhaust port directly.



- Optional suspension seat, bringing more comfortable drive



- Optional heating system



- 740mm wheelbase creating higher lateral and steering stability



- Hydraulic pilot controlling technology making it easy for drivers to control with only 1/3 control power of mechanical control



CONVENIENT MAINTENANCE

Open the cab, upper cover and rear door to complete all maintenance, convenient and quick



▪ Large upper cover tipping angle for easy maintenance

▪ Oversized cab for easy inspection

- Maintenance parts are reasonably arranged for easy maintenance;
- The extensive maintenance ports at the bottom of the body facilitates cleaning sediment and maintenance;
- Multi-function integrated instrument, oil volume, hour meter, voltage failure and other key equipment information can be displayed via LCD screen.

- A** Coolant filler
- B** Air filter
- C** Fuel filter
- D** Oil filter
- E** Fuel coarse filter

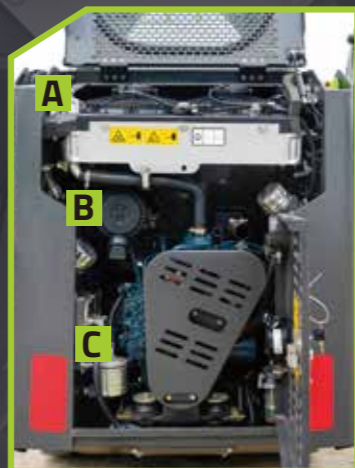

DISTINGUISHED & DURABLE

Core parts of well-known manufacturer, making work of machine more endurable



+



+



- Core parts of well-known manufacturer, with better stability and endurance;
- Bucket cylinders and pipelines are equipped with protective cover to prevent from being damaged.
- Key parts of bucket adopts NM400 wear-resistant steel plate with long life;
- Bucket teeth or blade is optional, longer bucket life, easier bucket loading.



MULTIPLE FUNCTIONS

Crushing, loading, carrying can be completed by one machine

It can be equipped with multiple attachments to meet different construction demands

- It can be equipped with breaker to complete crushing and loading;
- It can be equipped with fork to carry material easily;
- Used for loading, dodging, scraping, clamping, suitable for municipal construction, urban and rural gardens, road maintenance, mines, ports and so on.



FUNCTION CONFIGURATION

Standard configuration

- Adjustable seat
- Attachments hydraulic system
- Quick coupler
- Reverse alarm
- ISO control mode
- Horn
- 0.18m³ Bucket
- Integral instrument
- Lift arm safety support device
- Front & rear working light
- Safe interlocking device
- Two point safety belt
- Safety lever
- Built-in rearview
- Standard tire (Vacuum tires are not recommended by customers in the construction industry)
- General sign
- Opened cab (meeting ROPS, FOPS safety requirements certified by CE, rear window, power interface, reading light)

Optional configuration

	Note
▪ Heater assembly	
▪ Solid tire	Item 15 5.70-12NHS standard tire is cancelled; construction industry customers recommend the use of solid tires
▪ Revolving warning light	
▪ GPS/Domestic	Can not be equipped at the same time
▪ GPS/Abroad	
▪ Blade	Can not be mounted at the same time
▪ Bucket teeth	
▪ Chinese signs and delivery attached documentation	Only one language can be selected
▪ English signs and delivery attached documentation	
▪ Dust cover with quick couplings	
▪ Extinguisher	
▪ Closed cab	Opened cab and closed cab can not be equipped at the same time
▪ Emergency stop switch installation	
▪ Shock absorbing seat	Shock absorbing seat and standard adjustable seat can not be equipped at the same time

MAIN PARAMETERS

Type	Item	ZS030R
Overall dimension	Overall length (with bucket)	2460 mm
	Overall width (with bucket)	910 mm
	Overall height (height of top of cab)	1810 mm
	Height of bucket hinge pin	2420 mm
	Length of tail	695 mm
	Ground clearance	140 mm
	Angle of departure	25°
	Width of tire edge	910 mm
	Front turning radius(without bucket)	945
	Front turning radius (with bucket)	1460 mm
Work range	Rear turning radius	1115 mm
	Maximum working height	3070 mm
	Maximum dump height	1950 mm
	Dump angle at maximum height	34°
	Bucket rollback at maximum height	97°
Undercarriage parameters	Maximum angle of retracting bucket at ground level	23°
	Dump reach	403 mm
	Wheelbase	740 mm
	Tread	762 mm
	Tire specification	5.70-12 mm

Dimensions and work range diagram

