



**HANGCHA GROUP CO., LTD.**

Factory site: 666 Xiangfu Road,  
Hangzhou, Zhejiang, China (311305)

Tel: +86-571-88926735 88926755  
Fax: +86-571-88926789 88132890

[sales@hcforklift.com](mailto:sales@hcforklift.com) [www.hcforklift.com](http://www.hcforklift.com)



Follow us on  
Facebook



Follow us on  
YouTube



Follow us on  
WeChat



Download "Hangcha  
Forklift" App



ISO45001:2018



ISO14001:2015



ISO9001:2015



HANGCHA trucks conform  
to the European Safety  
Requirements.

# A SERIES

STAND-ON MAN-DOWN TURRET TRUCK

With capacity of 1,000 to 1,500kg

# A SERIES STAND-ON MAN-DOWN TURRET TRUCK

A series stand-on man-down turret truck is a new product special for narrow aisles developed by Hangcha. With advanced 48V permanent-magnet brushless electric attachment head, this stacker features advanced performance, comfortable operation, safety and reliability, and low cost of use and maintenance. The light weight of the whole stacker and the four-pivot structure for the chassis allow smaller equivalent load of floors, higher space availability of your warehouses, being an ideal tool to improve the capacity of your warehouses.

## DRIVING POSITION



The new design of the mast structure enables the stacker to have an excellent operating view and to access the pallet more easily.



A new layout provides a larger operating space. The low platform enables the operator to get on and off the stacker more conveniently.



- Designed with shock-absorbing function, the stand-on pedal can greatly improve the driving comfort and alleviate the driver's fatigue due to long-time driving.
- The newly-designed molded broad backrest is soft and comfortable, reducing operator's fatigue.



The thumb switch and the cross handle make the operation light and comfortable.



# MORE PROTECTION

The optimized suspension mechanism with a four-bar linkage makes the drive wheel and auxiliary wheel bear forces in an associative manner and reduces slippage of the drive wheel. The mechanical disc brake and regenerative braking system make the stacker's drive safer and more reliable.

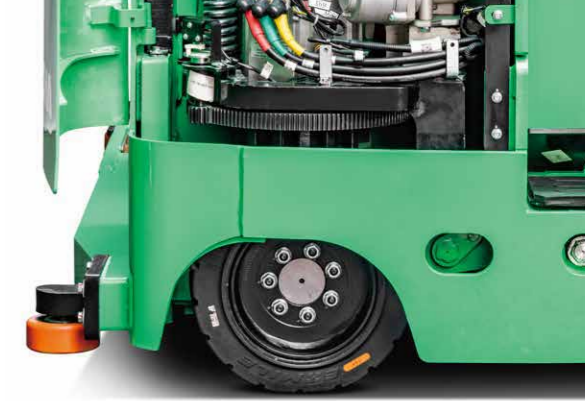

## SAFETY

- The turning deceleration function provided for the standard configuration makes the turning deceleration of the stacker smoother and safer.
- For the standard configuration, an in-place switch is provided for the driver to judge whether he/she is in the correct operating position. When not in the correct position, driving and hydraulic operations are prohibited.
- A brake interlock switch is provided. When the brake is released, the switch is triggered and driving is prohibited, except for hydraulic operations.

## RELIABILITY

- Relying on electric power-assisted steering, the steering is easy and the operation is adapted to road conditions. Even if the power steering system fails, the stacker still has the steering function, safe and reliable;
- The lithium battery with CATL core is adopted to realize high safety;

*The solenoid valve and gear pump can obtain better hydraulic efficiency and faster lifting speed;*



The adoption of mature mechanical disc brake allows emergency stop and parking, highly reliable.



With Curtis full AC controller, CAN communication is allowed, achieving both safety and reliability.

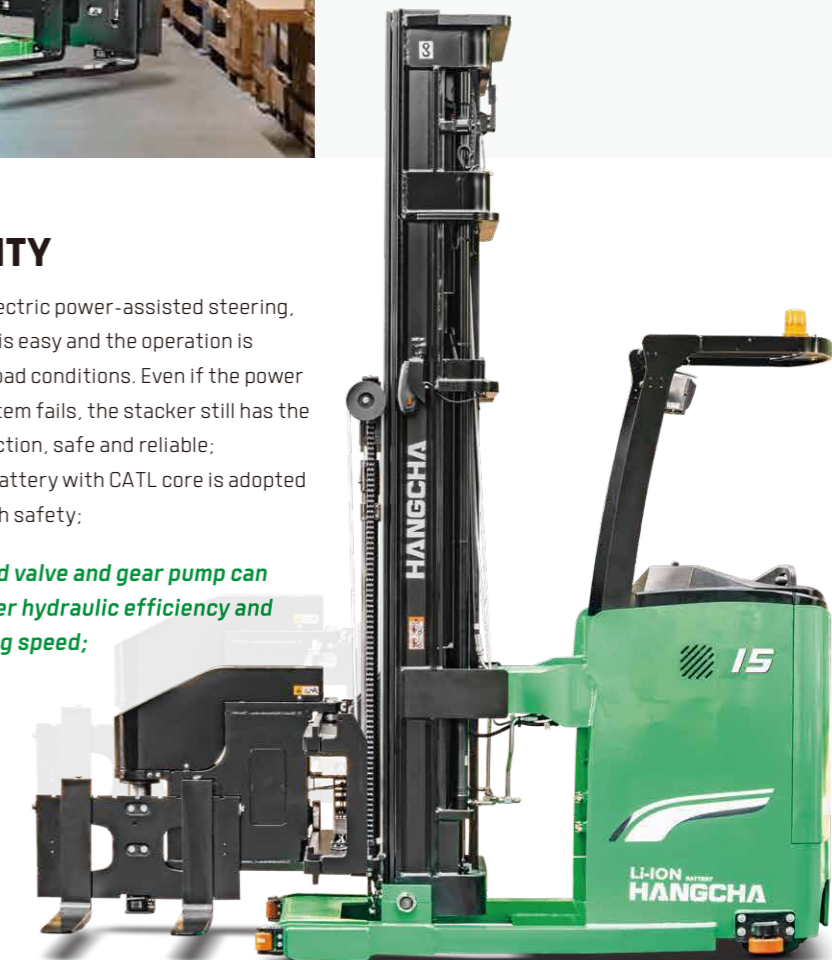





# MOVE LIKE YOU MEAN IT

## STABILITY

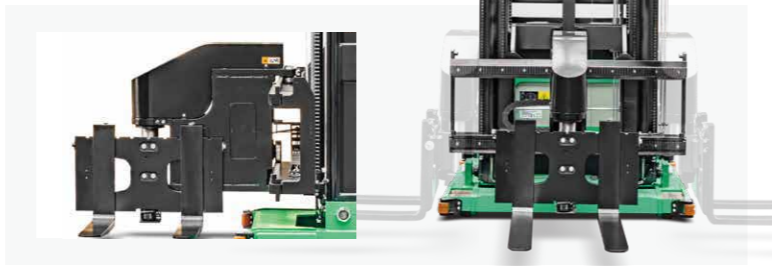
- In the new mast structure, the side roller structure is improved to meet the lateral requirements of the three-way stacker.



- The driving speed is related to the position of the attachment. If it is not in the normal position, the driving speed will be lowered in order to improve the stability of the whole stacker.
- The lifting speed is related to the position of the attachment. If it is not in the normal position, the lifting speed will be lowered in order to improve the stability of the operation.



After the mast is lifted to a certain height, the driving speed and the shaking of the mast are reduced, making the stacker safer.



The oil pump motor assembly is provided on the rear side of the stacker, so that the center of gravity of the whole stacker moves backwards and the stability is better.

**48V**  
V O L T A G E  
WITH  
PERMANENT MAGNET  
SYNCHRONOUS DRIVE MOTOR



## MAINTAINABILITY

- The electric attachment uses a permanent-magnet synchronous motor, thus free maintenance.
- With the 48V permanent-magnet synchronous electric power-assisted steering system, a permanent-magnet motor is used, relieving you from maintenance.
- With a hood that can be completely opened to expose all components and facilitate the maintenance of the vehicle.



The side movable battery is equipped for standard configuration, which are convenient for battery replacement and repair.

**LI-ION**  
TECHNOLOGY

HANGCHA provides Li-ion battery (LiFePO4) with 6 years or 12000 hours warranty.

## ENERGY SAVING AND HIGH EFFICIENCY

- The standard 48V permanent-magnet synchronous electric power-assisted steering system features, compared with 24V, lower current and energy consumption, and higher efficiency.
- The standard permanent-magnet synchronous electric attachment head features low noise, high efficiency and low energy consumption.
- The LED headlights and alarm lights for the standard configuration boast high brightness and low energy consumption.



With the wired camera, the trouble of replacing the battery in a wireless camera is avoided.



**6 YEARS**  
WARRANTY

# LITHIUM POWERED

EMPOWER YOURSELF  
WITH THE BEST



Li  
Lithium

POWER THE POSSIBILITIES  
RELIABLE LITHIUM-ION TECHNOLOGY



## LITHIUM BATTERY ADVANTAGES



### Long service life

4000 full charging cycles with at least 75% residual capacity.



### Return on investment

Add flexibility to your operation, cost-saving in the long term, increased efficiencies.



### Maintenance free

No topping up of water or checking acid levels.



### High energy density

The high energy density of the Li-Ion battery ensures long working times and increases the high availability.



### Cold area application

Li-Ion batteries maintain high performance at temperatures below freezing.



### High safety and reliability

Intelligent battery management monitoring every important function, no emission of battery gasses.



### Opportunity charging

Full performance during several shifts thanks to effective interim charging.

## FEATURES & BENEFITS THE HANGCHA DIFFERENCE

### Efficiency

By quick opportunity charging any downtime, such as a lunch break, can be efficiently used and the battery is recharged in a very short period of time. Interim charging does not affect the battery service life.

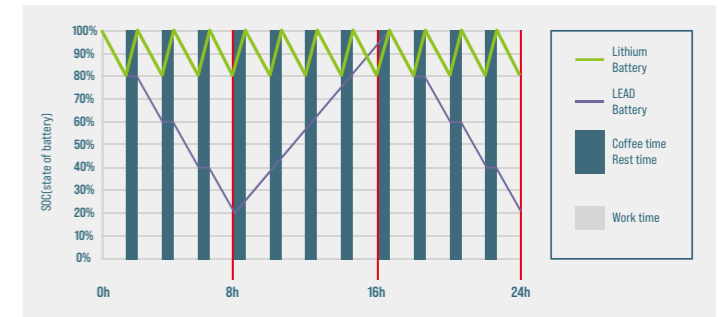

### Safety

- / Intelligent battery management monitoring every important function.
- / Higher user safety, thanks to acid-free use.
- / User friendly due to avoided battery change.
- / No emission of battery gasses.

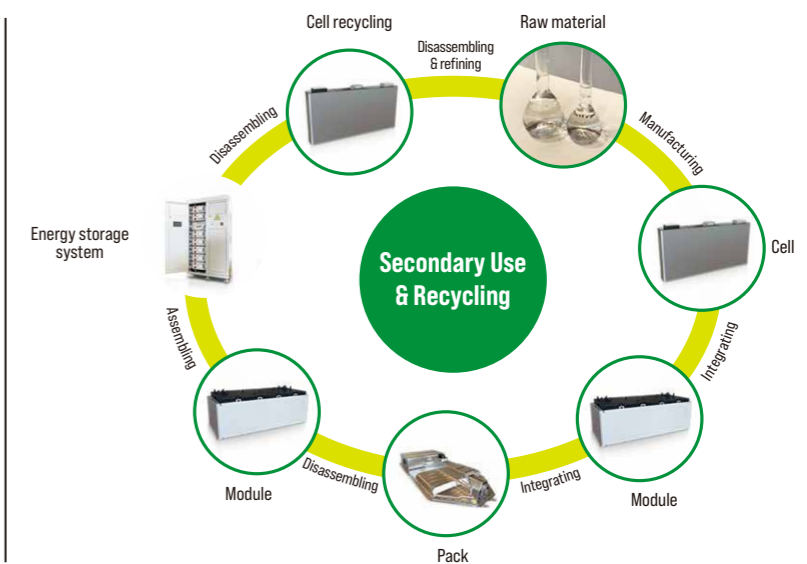

#### QUESTION 1

**Q: What are the characteristics of lithium batteries, especially when used in high and low temperature environments?**

Charging temperature: -30 C -65 C  
Discharge temperature: -30 C -65 C  
Storage environment temperature: -30 C -65 C

After the truck key switch is closed, the instrument battery condition needs to be checked:

1. Confirm that there is no battery system alarm message on the instrument panel.
2. Please check the remaining power before use. It is recommended to use the SOC between 50% and 100%.
3. If the SOC is lower than 20%, it is not recommended to continue using it. Please charge it as soon as possible.

#### QUESTION 2

**Q: What is the charging time and usage time calculation of forklift lithium battery?**

1. Available power of lithium battery (kWh) = rated voltage \* rated power \* 90% (To avoid over-discharge damaging the battery, the forklift is equipped with low power protection (less than 10%).)
  2. Charging time (h) = rated capacity of lithium battery (Ah) \* 90% \* charger output current (A).
  3. The power consumed for charging (kWh) = the available power of the lithium battery \* 93% (the charging efficiency of the charger is calculated as 93%).
  4. Usage time (h) = available power of lithium battery \* energy consumption data.
- For specific energy consumption values, please refer to the technical table on the sharing platform.**

#### QUESTION 3

**Q: How does Hangcha BMS work to ensure the safety of the lithium battery?**

HANGCHA BMS [battery management system] can monitor the cells at all times. As a result, hangcha lithium power is the reliable solution.



#### Battery Safety Management:

- Overcharge / over discharge protection
- Overcurrent / over-temperature / low-temperature protection
- Multi-level fault diagnosis protection
- Double fault monitoring



#### Battery Parameter Detection:

- Battery voltage detection and analysis
- Battery current detection and analysis
- Battery temperature detection and analysis



#### Equilibrium Management:

- Equalization based on voltage mode
- Equalization based on time mode
- Equalization based on battery cell SOC
- Active / passive equalization optional



#### Other Features:

- Low cost, low power consumption
- Historical data record
- Flexible cascade expansion
- CRC data validation

## Technical data

		HANGCHA GROUP CO.,LTD.				
Characteristics	1.1	Manufacturer (abbreviation)				
	1.2	Manufacturer's type designation	CSD10-AEC5S-I	CSD12-AEC5S-I	CSD15-AEC5S-I	
	1.3	Drive: electric	Electric	Electric	Electric	
	1.4	Operator type	Stand On	Stand On	Stand On	
	1.5	Rated capacity/rated load	0 (kg)	1000	1200	1500
Weight	1.6	Load centre distance	c (mm)	550	550	550
	1.9	Wheelbase	y (mm)	1650	1650	1650
Wheels	2.1	Service weight(incl.battery)	Kg	4130	4240	4260
	3.1	Tyres: solid rubber, superelastic, pneumatic, polyurethane	Drive/front	Rubber/Polyurethane	Rubber/Polyurethane	Rubber/Polyurethane
	3.2	Tyre size, front	mm	Ø380x165	Ø380x165	Ø380x165
	3.3	Tyre size, rear	mm	Ø127x98	Ø140x127	Ø140x127
	3.4	Additional wheels (dimensions)	mm	Ø204x76	Ø204x76	Ø204x76
	3.5	Wheels, number front/rear (* - driven wheels)		1x,2/4	1x,2/4	1x,2/4
	3.6	Tread, front	b10 (mm)	685	685	685
Dimensions	3.7	Tread, rear	b11 (mm)	1230	1300	1300
	4.2	Height, mast lowered	h1 (mm)	2250	2500	2500
	4.3	Free lift	h2 (mm)	60	60	60
	4.4	Lift	h3 (mm)	3000	3000	3000
	4.5	Height, mast extended	h4 (mm)	3525	4025	4025
	4.7	Height of overhead guard (cabin)	h6 (mm)	2300	2300	2300
	4.8	stand height	h7 (mm)	350	350	350
	4.19	Overall length	l1 (mm)	2964	2964	2964
	4.20	Length to face of forks	l2 (mm)	2740	2740	2740
	4.21	Overall width	b1/b2(mm)	1380/1406	1480/1506	1480/1506
	4.22	Fork dimensions DIN ISO 2331	s/e/l (mm)	40x122x920	40x122x920	40x122x920
	4.24	Fork-carriage width	b3 (mm)	800	800	800
	4.27	Width across guide rolls	b6 (mm)	1450	1550	1550
	4.29	Reach,lateral	b7 (mm)	1160	1260	1260
	4.30	Reach,lateral from vehicle centreline	b8 (mm)	395	445	445
	4.32	Ground clearance,centre of wheelbase	m2 (mm)	50	50	50
	4.34	Aisle width for pallets 1100*1100	Ast (mm)	1550	1650	1650
	4.35	Turning radius	Wa (mm)	1910	1910	1910
	4.38	Distance to swivelling-fork pivot	la (mm)	655	655	655
Performance	5.1	Travel speed,laden/unladen	km/h	9/9	9/9	9/9
	5.2	Lift speed,laden/unladen	mm/s	340/420	330/420	300/410
	5.3	Lowering speed,laden/unladen	mm/s	550/550	550/550	550/550
	5.4	Reaching speed,laden/unladen	mm/s	230/230	230/230	230/230
	5.8	Max.gradeability,laden/unladen	%	10/10	10/10	10/10
	5.10	Service brake		Regenerative+Mechanical	Regenerative+Mechanical	Regenerative+Mechanical
E-motors		Parking brake		Mechanical	Mechanical	Mechanical
	6.1	Drive motor rating S2 60 min	kW	AC 5	AC 5	AC 5
	6.2	Lift motor rating at S3 15%	kW	AC 11	AC 11	AC 11
	6.4	Battery voltage/nominal capacity K5	V/Ah	48/228	48/228	48/302
	Battery weight	kg	180	180	200	

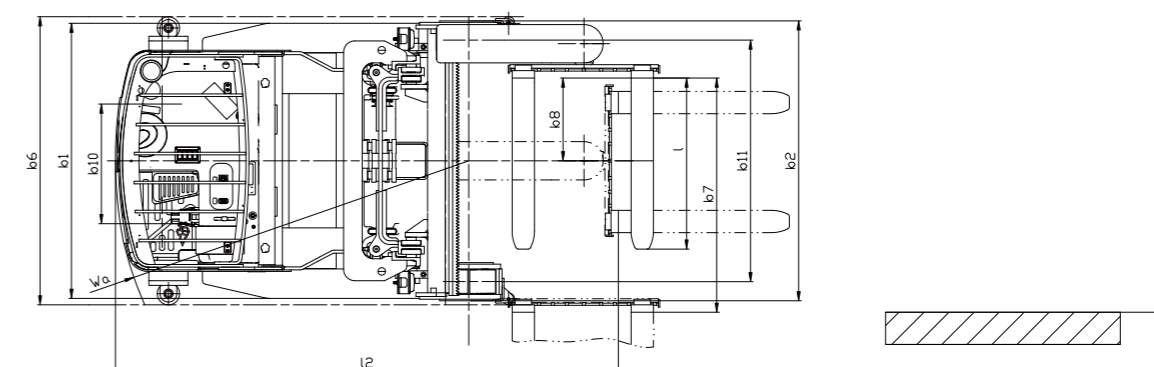
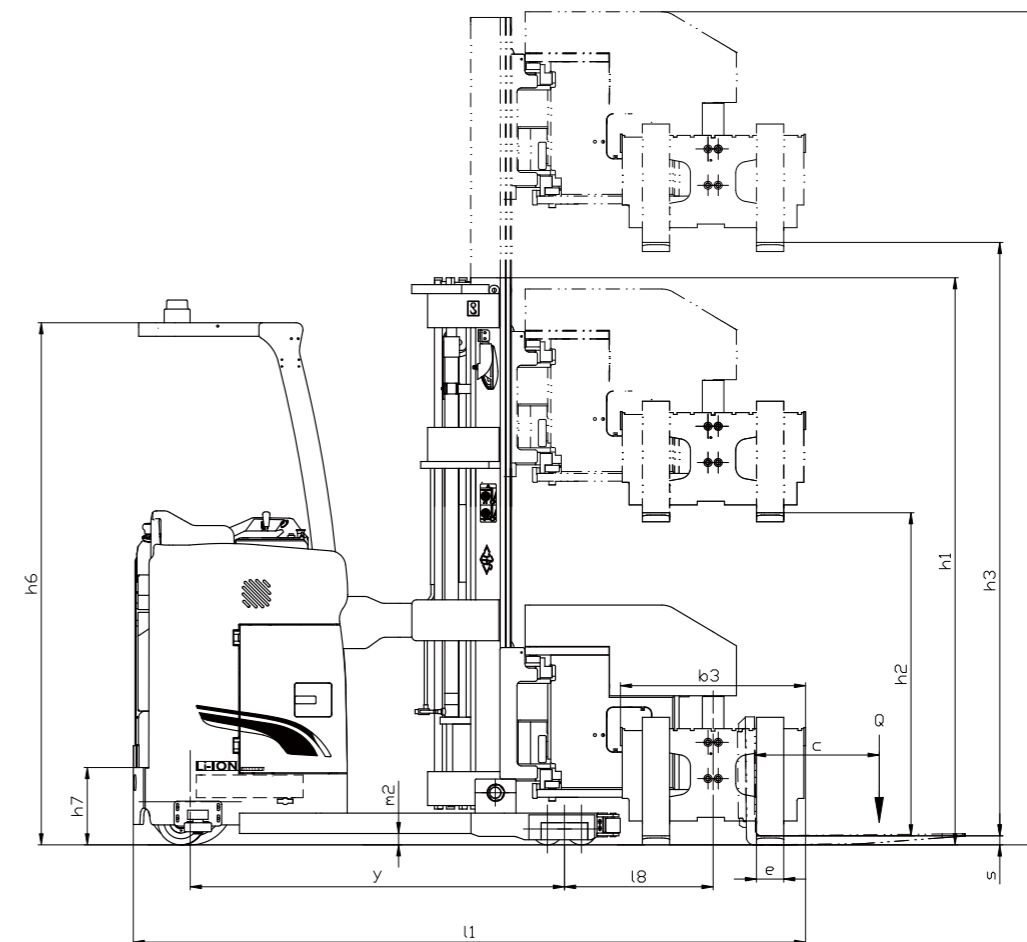

## Battery capacity

Type		CSD10-AEC5S-I	CSD12-AEC5S-I	CSD15-AEC5S-I
Battery voltage, capacity	V/Ah	48/228	48/228	48/302
Option capacity	V/Ah	48/302	48/302	/
Titans charger		SLC-48100	SLC-48100	SLC-48100
Option capacity	V/Ah	48/456	48/456	48/456
Titans charger		SLC-48200	SLC-48200	SLC-48200

## 1.0t Mast Specification

Type	Model	Lifting height h <sub>3</sub>	Mast lowered h <sub>1</sub>	Mast extended h <sub>4</sub>	Free lifting height h <sub>2</sub>	Load capacity center at 550mm	
		mm	mm	mm	mm	1.0t	
						kg	
Wide view duplex mast	ASS10MX	3000	2250	3525	60	1000	
	ASS10MX	3500	2500	4025	60	1000	
	ASS10MX	4000	2750	4525	60	1000	
	ASS10MX	4500	3000	5025	60	1000	
	ASS10MX	5000	3250	5525	60	1000	
	ASS10MX	5500	3500	6025	60	1000	
	ASS10MX	6000	3750	6525	60	1000	
Full free triplex mast	ASS10DX	4500	2350	5025	1300	1000	
	ASS10DX	5000	2500	5525	1500	1000	
	ASS10DX	5500	2675	6025	1650	1000	
	ASS10DX	6000	2850	6525	1800	1000	
	ASS10DX	6500	3000	7025	2000	1000	
	ASS10DX	7000	3175	7525	2150	900	
	ASS10DX	7500	3350	8025	2300	800	

## 1.2-1.5t Mast Specification

Type	Model	Lifting height h <sub>3</sub>	Mast lowered h <sub>1</sub>	Mast extended h <sub>4</sub>	Free lifting height h <sub>2</sub>	Load capacity center at 550mm	
		mm	mm	mm	mm	1.2t	1.5t
						kg	kg
Wide view duplex mast	ASS15MX	3000	2500	4025	60	1200	1500
	ASS15MX	3500	2750	4525	60	1200	1500
	ASS15MX	4000	3000	5025	60	1200	1500
	ASS15MX	4500	3250	5525	60	1200	1500
	ASS15MX	5000	3500	6025	60	1200	1500
	ASS15MX	5500	3750	6525	60	1200	1300
	ASS15MX	6000	4000	7025	60	1150	1200
Full free triplex mast	ASS15DX	4000	2350	5025	1300	1200	1500
	ASS15DX	4500	2500	5525	1500	1200	1500
	ASS15DX	5000	2675	6025	1650	1200	1500
	ASS15DX	5500	2850	6525	1800	1200	1300
	ASS15DX	6000	3000	7025	2000	1150	1200
	ASS15DX	6500	3175	7525	2150	1100	1150
	ASS15DX	7000	3350	8025	2300	1050	1100
ASS15DX	7500	3500	8525	2500	1000	1050	

## Features

Truck	Standard	Options
48V permanent-magnet synchronous electric attachment head	●	
48V permanent-magnet synchronous electric power-assisted steering	●	
Fork descending buffering (cylinder buffering)	●	
Rubber driving wheel	●	
Polyurethane (load wheel + auxiliary wheel)	●	
Lithium battery	●	
Ascending buffering	●	
Solenoid valve	●	
Removed from the side of battery	●	
Height selection		○
Cold storage vehicle		○
Lithium battery 48V/456Ah (CATL)		○
USB plug	●	
Reflective mirror		○
Controls and instruments		
Altimeter		○
Cigarette lighter		○
Code lock and card swiping		○
Card reader (independent card reader)		○
Fingerprint lock (independent fingerprint lock)		○
Interactive instruments	●	
AC driving + AC lifting	●	
Automatic turning deceleration	●	
One-click fork linkage and one-click centering		○
Safety		
Emergency shut-off switch	●	
Regenerative braking (reversing, neutral, braking)	●	
In-place switch (people sensing)	●	
Horn	●	
Camera	●	
Reverse buzzer	●	
Reverse voice buzzer		○
Fire extinguisher		○
Lights		
Alarm light	●	
Blue lights, straight projection lights		○
Acoustic and optical alarm light		○